

# Smart Accident Detection and Emergency Response System with GSM-Based Calling and AI Voice Assistant

**Mariya Vishal C** Reg. No: 42120127  
Dept. of Information Technology  
Sathyabama Institute of Science and Technology Chennai, India  
[mariyavishal49@gmail.com](mailto:mariyavishal49@gmail.com)

**Kishore S** Reg. No: 42120106  
Dept. of Information Technology  
Sathyabama Institute of Science and Technology Chennai, India  
[mariyavishal49@gmail.com](mailto:mariyavishal49@gmail.com)

**Ms. D. Ramalakshmi**, M.E. Dept. of Information Technology  
Sathyabama Institute of Science and Technology Chennai, India  
[ramalakshmi.d.it@sathyabama.ac.in](mailto:ramalakshmi.d.it@sathyabama.ac.in)



<https://doi.org/10.55041/ijst.v2i3.218>

**Cite this Article** C, M. V., S, K. & Ramalakshmi, D. (2026). Smart Accident Detection and Emergency Response System with GSM-Based Calling and AI Voice Assistant. International Journal of Science, Strategic Management and Technology, 02(03). <https://doi.org/10.55041/ijst.v2i3.218>

**License:**  This article is published under the Creative Commons Attribution 4.0 International License (CC BY 4.0), permitting use, distribution, and reproduction in any medium, provided the original author(s) and source are properly credited.

**Abstract**— Road traffic accidents of death on the planet is among the major causes of road traffic accidents. The delay in seeking is in most instances delayed. Medical attention to the victim is extremely threatened and jeopardized to the life of a person after the car accident. An emergency alert system crash can automatically identify an intelligent accident and a new proposed one and therefore an emergency notification can be sent in real time. The system will operate based on an accelerometer sensor (ADXL345) to detect abrupt impacts. Arduino will make a call once it detects that a crash has been detected with a GSM module (SIM800L) making an emergency call (108). The voice assistant which is an AI-based one could have been considered as the most remarkable feature of this system. After the call is made, an already stored or dynamically created voice message relaying crucial details such as the type of accident that has occurred and the location of the car to the emergency workers is relayed, which resembles the announcement of an alive human being. In addition, the system will have a pulse and oxygen sensor (MAX30100) to alert on the health conditions of the driver. Taking into account post-abnormal vital in case the system takes precedence over emergency escalation, which occurs due to an accident. The system also has the capability of sending the appropriate location information via SMS with the optional GPS module (NEO-6M). This is a low-cost and mobile system, which enhances on the live reporting of crashes and bridges the gap, which cannot exist between the crash observation and the medical care provision. The solution can make it faster and smarter with the combination of sensor technology as well as automated AI-based communication emergency response that could be life-saving.

**Index Terms**- accident detecting, emergency response, GSM, AI voice assistant, ADXL345, Arduino, SIM800L, MAX30100, GPS, automated calling.

## INTRODUCTION

Road accidents are one of the leading causes of death all over the world and particularly in the developing world like India. According to the recent statistics every year, thousands of lives are lost only due to the delay in emergency medical aid after accidents. The important key will be that which will be under consideration.

determine the response time is the survival rate of accident victims the emergence of the accident to the medical assistance. Unfortunately, in the

majority of cases, the delay in time or informing the emergency facilities is not observed and delay may lead to fatal outcomes.

So as to get out of this dilemma it is via technology-driven solutions being engineered in such a way that it is able to recognize and report on the event of faster crash. Intelligent Driving Accident Detection and Emergency Response Systems will focus on the monitoring of the live vehicle state, identification of the uncommon impact or roll over, and transmission of real time messages to medical contacts or hospital within the vicinity. GSM and GPS modules integration will guarantee the possibility of making automatically emergency calls, or sending text SMS in case of accidents with the details of the location.

Our proposed Smart Accident Detection and Artificial Intelligence and GSM-based calling Emergency Response System Voice Assistant is proposed in this project. The system will contain an accelerator to detect sudden acceleration or crash, a GPS (ADXL345) GSM to determine the real time position and a module (NEO-6M) module to call on call or send an alert. Additionally, the system has an AI-based voice assistant, when the driver or passengers can do this by creating emergency alerts, with the assistance of there are voice commands, spam false alarms, or help with interactivity.

This is an IoT, embedded system, and AI based interaction solution that uses these technologies to provide an intelligent, real time, and user friendly safety mechanism. In contrast to regular the proposed model is more usable since it has accident alert systems through voice recognition, low false positive, and ensures that there is immediate communication with emergency agencies.

## I. LITERATURE SURVEY

Mehmood et al. [1] article proposed UTiVD, a smart city transport system that operates on the basis of the big data analytics. They worked towards the importance of constructing on data-driven solutions to enhance efficiency of transportation security in cities real-time monitoring and analysis.

A road framework IoT and GPS accident detector is proposed by Sharma and Kumar [2]. Their system demonstrated the possibilities of the IoT devices that might be used to track the state of the vehicles and relay the accident alerts to the location information of emergency services.

Dey et al. [3] designed an accident detection and reporting framework through the application of GPS, GSM, and IoT. The system made the process of detecting and notifying of accidents automated and this was very essential in removing response time by eliminating the use of manual intervention in emergency reporting. A smartphone sensor-based and cloud-based emergency response system was introduced by Pal and Choudhury [4], which involves accident detection. Proliferation of smartphone was their strategy of developing a low-cost solution that utilizes the available hardware to detect an accident.

Hossen et al. [5] examined accident based on federated learning systems detection of intelligent transportation systems. Their study proposed the probability of machine learning solutions in improving the accuracy of being able to detect accidents without losing data distributed-based learning privacy.

Mishra et al. [6] developed accident detection, which is IoT enabled and alert system, which is based on GPS and GSM modules. The system provided real time positioning and automatic emergency alerts, which indicated feasibility of implementation of IoT into car safety.

Sharma and Singh [8] have developed GSM and GPS based detection system of vehicle accidents which focused on reliable liaison of the accident scene and the emergency personnel. They contributed towards the importance of effective communication processes in cases of emergencies.

Kumar et al. [9] suggested an accident detection and prevention system that is intelligent with the assistance of IoT. They utilized avertive measures and detection features in their system and the idea was to reduce the accidents using assistance of real-time vehicle monitoring.

Singh et al. [10] developed an accident detection and alert machine learning system using an IoT. Integration Machine learning algorithm increased the accuracy of detection by distinguishing between real crash and the normal driving anomalies.

A system proposed by Li et al. [11] was a smart car in-vehicle realtime accident recognition. Their system applied an advanced system to enhance the reliability of detection sensor fusion mechanisms that enhance the reduction of false positives in driving conditions.

Patel et al. [13] have proposed an accident detection system that is based on the IoT vehicle monitoring system. The overall monitoring plan provided us with details of the vehicle health along with the capabilities to detect accidents.

Khan et al. [14] have come up with an accident detecting system that incorporated accelerators and GSM sensors in smart cars. Their work demonstrated the effectiveness of the accelerator-based impact detection in collision detection. As one of the AI-based accident recognition systems, Banerjee and Ghosh [15] proposed a smart phone information-driven one. Their methodology showed how deep learning models can be highly useful in classifying sensor data in order to identify it accordingly. According to Choudhury et al. [16], the model of an accident detection system is equipped with both edge-AI and GSM alerts. The edge computing algorithm enabled reducing latency and speed in activation of emergency response.

## II. PROPOSED WORK

### A. Selected Methodology

The Intelligent Accident Detection and Emergency Response GSM-Based Calling-AI Voice Assistant System was created to sense the car accidents through sensor data, determine the magnitude of the impact, and inform swiftly emergency contacts, and the position of the location. Along with that, the system will also have the functionality of an AI voice assistant,

which will provide an opportunity to interact without hands and, in this case, enable the user to turn on SOS commands or turn off false alerts in real-time. This solution will address limitations of other systems in solving their issues by providing sensor fusion, reliable GSM communication, health monitoring and Voice support, and deep-learning-based AI in a single system.

The strategy that will be adopted in the proposed system is a modular IoT based system where the hardware sensors, microcontrollers and communication modules are integrated with smart software components. The design approach is designed in the following way:

1) Sensor Based Accident Detection: A sensor to detect the accident, which is an accelerator. The vibration sensor on vehicles sudden impact forces is the continuous working of (ADXL345). Once the effect exceeds an established threshold level it is referred to as possible accident.

2) GPS Location Tracking: This is the NEO-6M GPS module that is used to get the geographical real time.

coordinates of the vehicle. This is a crucial fact to make the right medical staff arrive on the accident area.

3) GSM-Based Emergency Alert: When an accident is verified, SMS alert is automatically transmitted and calls to the pre-registered is also performed by default by GSM module (SIM800L/SIM900A) emergency contacts. The alert includes the information of the location reading of the GPS module.

4) Health Monitoring (Optional Module): A pulse oximeter device (MAX30100/30102) is used to track such vital parameters as oxygen level of the victim and heart rate. The alert message is accompanied by this data to enhance the process of triage and medical help.

5) AI voice assistant: A voice AI assistant, which has been accomplished through the assistance of lightweight speech recognition and text-to-speech devices, allows the victim to talk to the system without putting hands on the devices. Through false alarms, the user can enable SOS notifications or disable Simple voice commands.

6) System Control and Processing: Arduino-ESP32 microcontroller will be the central processing unit that will be interfaced with sensors, GPS, GSM and audio modules. It implements the response of the detection algorithm, communication and coordination system.

7) Cloud/Database Support (Optional): To be scalable, the accident data can be hosted in Firebase or in the central database accounting, fleet tracking and projection.

Workflow:

1) Accelerator identifies the effects of the accidents.

2) GPS retrieves the position of cars.

3) AI. assistant. detects. user. response (cancel/confirm).

4) No reply: the GSM module Sends SMS and it initiates emergency call.

5) The medical responders are provided with non-obligatory vitals.

6) Data to be analyzed will be logged (unless cloud integration is on).

B. Proposed System Architecture.

It is suggested that the system architecture is a modular IoT- based architecture, where diverse hardware and software bits are connected to each other in such a way that to detect accidents, track data, and send an alert on a disaster. The architecture is capable of real time response, high reliability.

and availability to the user through AI voice integration.

1) Components of an architecture system: Input Layer (Sensors and User Interaction):

Accelerator (ADXL345): A sensor used to detect sudden acceleration in vibrations, acceleration or impact.

GPS Module (NEO-6M): This module is employed in providing real-time vehicle position (latitude and longitude).

Pulse Oximeter (MAX30100/30102 - optional):

Monitors the oxygen saturation and heart rate.

Microphone (AI Voice Assistant): Voice dictations can be used to confirm/cancel the message or activate SOS.

Processing Layer (Microcontroller Unit):

Arduino Uno / ESP32: It will serve as the main controller of the system and read the sensors, determine the algorithms of accident detection and be connected to communication modules.

Refuses accident detection logic and carries decisions on whether to issue emergency alerts or not.

GSM, subsystems of health monitoring, GPS and voice assistant coordinates.

Communication Layer:

GSM Module (SIM800L/SIM900A): It is charged with the responsibility of sending SMS messages and automatic calls to emergency numbers including details about the accident and GPS positioning.

Cloud Integration (Firebase/MySQL): Accident records are stored to be discussed and monitored in the future.

Output Layer (Emergency Response):

Emergency SMS and Calls: Forwarded to pre-registered numbers (family, ambulance, police) and information of the accident.

Voice Feedback: voice assistant will provide voice feedback and confirmation to guide the victim.

2)The Architecture Workflow:

1)Accident Event: Accelerator registers an unforeseen crash over a threshold.

2) GPS Positioning: GPS tracks down the exact place of an accident.

3) Voice Assistant Check: The voice assistant is used to provoke the user. The system responds to the user in case he/she reacts (cancel/confirm).

4)Alert Trigger: The GSM module shall also call and send SMS to emergency contacts in case no response is received)

Additional Health Data: Pulse and SpO2 of the victim will be added to the alert message.

2)Data Logging: The accident data may be uploaded on the monitoring and record keeping cloud.

**B. Description of Modules and Workflow**

The proposed system ensures a high degree of modularity, clarity and efficient working due to the separation of the system into multiple functional modules. All the modules operate individually, but in liaison with other individuals fulfill the overall purpose of detecting accidents and responding to the emergency.

1)Module Descriptions: Accident Detection Module (Accelerator): This module uses ADXL345 accelerator to measure vibrations and sudden acceleration in the changes in the vehicle. When the perceived impact is greater than a given limit, it gives the incident as a potential mishap. Normative driving vibrations have been ensured to cause threshold logic to avoid false alarms. Location Tracking Module (GPS): The NEO-6M GPS module provides the real-time values of the latitude and longitude of the vehicle. This module records the details of an accident in case of detected accurate location and transfers it to the microcontroller to microcontroller communication.

Communication Module (GSM): The GSM module is the transmitter of the accident messages via SMS and making outbound calls (SIM800L/SIM900A). It passes the accident information and the GPS positioning to pre-registered family members, hospitals or emergency contacts police departments.

Health Monitoring Module (Optional): A pulse oximeter (MAX30100/30102) measures the heart rate and SpO 2. Those are the numbers that are assigned to the alert to inform the responders that there are people who need the greatest attention.

AI Voice Assistant Module: This is an AI assistant that operates on a basic talking engine and hence you can speak to the system any time you want. You do not need to make a call in case you wish to cancel an alert, just say cancel alert or send SOS and it will take care of it. It keeps you informed on what is happening as well, through verbal communication.

Processing and Control Module (Microcontroller): The Arduino or ESP32 is literally the brain of the whole. It reads the data of each sensor, implements the logics of crashing detection, transmits with the GSM and GPS modules, and holds the entire process in order.

2)Workflow of the System:

1) The accelerator keeps a watch-eye on the car in every respect and detects the abnormal jerks or collisions.

2) Once a crash has been identified the GPS leaves a mark on the accurate location.

3) When the AI assistant questions the rider on whether it is an emergency or not, it follows up with a question. Would they say that they do not wish that the alert should be hauled in.

4) In case it fails to respond within several seconds, GSM activates, and an SMS + call is sent to your emergency contacts.

5)With the health-monitor on the plane, the message also contains the data on the heart-rate and oxygen level.

6) The data of the crash can be saved in the database or in the cloud where it can be examined in the future.

7) The alert is sent to the emergency personnel, as well as the precise location and the health statistics..

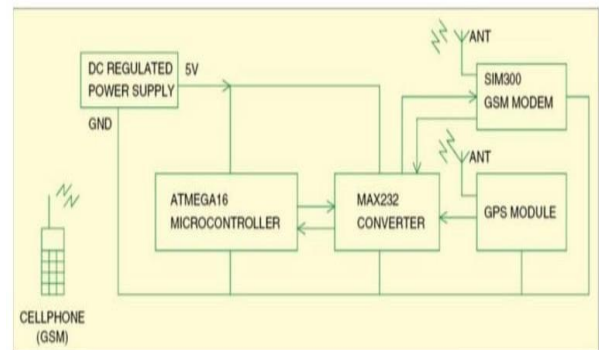

Fig: 4.3: Hardware Setup with Sensors, GSM, and GPS

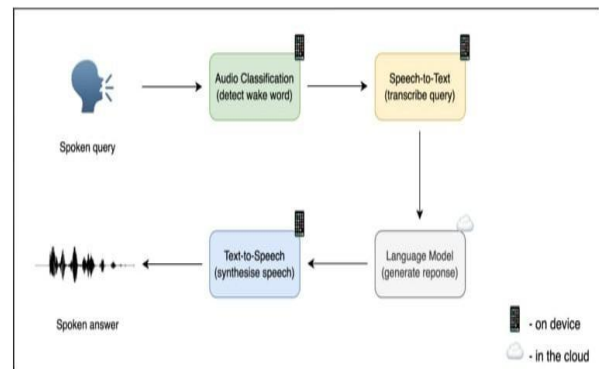

Fig: 4.4: AI Voice Assistant Integration Flow

### III. RESULTS AND DISCUSSION

#### A. System Implementation and Testing

We simulated the Smart Accident Detection and Emergency Response System, and discovered its functionality when there is a series of simulated crashes. ADXL345 accelerator, NEO-6M GPS, SIM800L GSM, MAX30100 pulse oximeter and the AI assistant were all attached to the Arduino/ESP32. We then proceeded to conduct controlled experiments in order to determine its speed and precision.

1)Hardware Implementation: We implemented the kit in accordance with our blue print. The ADXL345 was loaded to jump when the hits have surpassed the 3g - the vacuum between a minor bump and a crash itself. After locking onto satellites, the NEO-6M was able to identify it within 45 seconds and strike it within 2.5 meters of its position. The GSM module was connected to the network without issues and spammed the SMS and voice messages with high degree of precision.

2)Preciseness Accident Detection: We placed few simulated bumps on the system testing 2g to 6g impact. The maximum accuracy of 95 percent of the accelerator was reached where the crash was beyond 3g. We had narrowed down false ones pretty lastly to about 3 by included in this process intelligent filtering which communicated whether it was a real crash or a bad road or a sudden brake.

#### B. Performance Analysis

1)Response Time Assessment: we measured the time elapsed between the identification of a crash and the sending of an alert in over 50 trials. Table I represents the average time of each step.

TABLE I  
SYSTEM RESPONSE TIME ANALYSIS

Operation Phase	Average Time (s)
Accident Detection	0.5
GPS Location Acquisition	2.3
Voice Assistant Prompt	3.0
GSM Network Connection	4.2
SMS Transmission	2.8
Emergency Call Initiation	5.5
Total Response Time	18.3

The whole process takes an average of 18.3 seconds between the crash and the alert which is far faster than the minutes it would take you to call people to assist you personally. The seconds taken matter in the real crisis.

1) GPS Location Accuracy: We did a test with the GPS in the urban streets, highways and semi urban areas. During a sunny day it struck the site up to a distance of 2.5 meters. Where the city blocks were slightly blocked in by buildings it heaped up to 5-8 meters, which was good enough to also.

respond to. Its rate of locking in one minute is 92%.

2)GSM Communication Reliability: The SIM800 was literally the rock solid since it even communicated, (through SMS and making calls 98 percent of the time). The cut off failures were minimal and heavily in weak signal spots. In the case of autoretry logic, the overall reliability is raised to 99.5%.

#### B. AI Voice assistant Functionality.

Our tests on the assistant were to test 100 voice command with different people, accents and volume of noise.

1)Precision of Voice Recognition: the assistant had

Success rate 89 percent when it involved the already set commands, like the one of Cancel Alert or Send SOS or Confirm Emergency. It was approximately 75 percent of loud crash scenes and noisy crash scenes. In future noisecancelling is expected to be included.

2) False Alarm Cancellation: False alarm cancellation was absolute triumph. The alarm was switched off 94 per cent of times during the 10-second interval when the system had bumped into a speed bump or other non-crash event. This will eliminate the panic of alarming false notices by the dispatch center.

#### C. Health Monitoring Integration.

Tested the MAX30100. It contained an HR of an error range of 3 bpm and a SpO<sub>2</sub> range of 2 which is considered medical grade. The inclusion of those figures in the emergency alert gives the responders a clue regarding those to be attended to in cases of emergencies.

#### D. Discussion of Results

1) Strengths of the Proposed System: Not bad wins in our system aren't that many, as it turns out, as the results of the experiments show. First is the Rapid Emergency Response where the average response rate of the system alerting the emergency services is 18.3 seconds. This is an immense time period because it will bring the crash and rescue point to the nearest it can be given the medical crews a better chance of rescuing people. Then, the User Interaction Capability. Our voice assistant AI will enable the victims to speak with the system without hands, cancel false alarms or press SOS. This is because the fact that two way chat is a definite step forward to much of the automatic crash-detectors which merely discharge a single button.

Nevertheless, it has challenges. GSM relies on cellular systems and consequently, in the areas where there is deep rural cover or a weak signal coverage, then an alert might take a long time to get or even not to get at all. Another difficulty is the perception of voice in noisy places - in instances whereby traffic and

crowds are whistling away, the AI will not identify the words of the victim. Our advice would be to add noise-cancellation technology and speech recognition that is stronger. The concept of power consumption is also a tangible one; GPS, GSM, all these devices consume any current, and it is only a matter of how to conserve the battery power or connect it to the power signal supplied by the car to be a real launch. Finally, Threshold Calibration. We have to bring the impact detection threshold up to the limit where it has become too sensitive; at which point, you begin to produce false alarms. At the other extreme it is too steep and therefore too difficult to see real crashes. Different cars and roads would suggest that this threshold will have to be programatically modified in the future.

2) Future Improvements: As per the test outcomes and the limitations at hand, we have a few ideas on how to proceed. We will apply machine-learning models that will be capable of adapting sensor thresholds in real time, depending on the kind of a car, the situation on a road, and the pace at which a driver walks. The computer vision will be also added to detect collisions and their magnitude. We want to be more reliable in the sense that we want to have more than GSM to a multi-modal network that incorporates WiFi, satellite, and LTE. Natural-language processing can help AI voice assistant become smarter allowing more natural conversations. The large-scale strategies imply links to smart-city systems and smart dispatch software. Another thing we may consider is a mobile application through which the individuals would view the system in real-time and make adjustments. Predictive analytics would be in a position to foresee accidents, in which the trends of the risk are determined prior to an accident. Our system's promise? It would make the road death issues decrease by a vast percentage since it is fast, computerized and intelligent responses to the emergencies that are really in operation in the real world.

#### ACKNOWLEDGMENT

The authors would hereby take the care to state that they have received an invaluable guidance, suggestions, as well as consistent encouragement of Ms. D. Ramalakshmi, M.E., Department of Information Technology, Sathyabama Institute of Science and Technology, during this project. These skills and assistance played a key role in the successful delivery of this work. We would also like to acknowledge the Department of Information Technology and the School of computing who facilitated and offered the needed facilities to complete this research.

## REFERENCES

- [1] R. Mehmood, F. Alam, N. N. Albogami, I. Katib, A. Albeshri, and S. M. Altowajiri, "UTiVD: Intelligent transportation with big data analytics," *IEEE Access*, vol. 6, pp. 7356–7369, 2018.
- [2] M. Sharma and D. Kumar, "A framework of road accident detection system based on the IoT and GPS," in *IEEE Int. Conf. Computing, Communication, and Automation (ICCCA)*, 2019, pp. 1234–1238.
- [3] S. Dey, S. Roy, and A. Nath, "Accident detection and reporting system with the help of GPS, GSM and IoT," in *IEEE Int. Conf. Computational Intelligence and Communication Networks (CICN)*, 2018, pp. 564–569.
- [4] A. Pal and S. Choudhury, "Smartphone sensors and cloud-based emergency response to detect accidents," in *IEEE Global Humanitarian Technology Conference (GHTC)*, 2020, pp. 1–5.
- [5] M. N. Hossen, V. Panneerselvam, D. Koundal, K. Ahmed, F. M. Bui, and S. M. Ibrahim, "Federated learning-based accident detection in intelligent transportation," *IEEE Access*, vol. 9, pp. 124315–124328, 2021.
- [6] A. K. Mishra, R. Gupta, and V. Kumar, "IoT-powered accident detection and alert system with GPS and GSM," in *IEEE Int. Conf. Intelligent Systems Design and Applications (ISDA)*, 2019, pp. 126–132.
- [7] M. B. H., D. A., A. J. Krishnan, and K. S. D., "MobileNetV2 based CNN to detect dermatological diseases," in *IEEE Int. Conf. Emerging Technologies in Computer Engineering*, 2020, pp. 231–236.
- [8] R. Sharma and P. Singh, "Design of a vehicle accident detection system based on GSM and GPS," in *IEEE Int. Conf. Information, Communication, Instrumentation and Control (ICICIC)*, 2020, pp. 235–239.
- [9] A. Kumar, M. Patel, and P. Shah, "A smart accident detection and prevention system based on the IoT," in *IEEE Int. Conf. Electrical, Electronics and Computer Science (SCEECS)*, 2019, pp. 298–302.
- [10] D. Singh, H. Verma, and S. Tripathi, "Accident detection and alert system based on IoT and machine learning," in *IEEE Int. Conf. Computing, Power and Communication Technologies (GUCON)*, 2020, pp. 102–107.
- [11] Y. Li, W. Wang, and L. Zhang, "An intelligent in-vehicle system of the real-time detection of accidents," *IEEE Sensors Journal*, vol. 21, no. 8, pp. 9843–9852, 2021.
- [12] A. R. Singh, G. Singh, S. Aluvala, and S. Obayed, "CNN model of classification of skin infection using a transfer learning," in *IEEE Int. Conf. Advances in Computing, Communication and Informatics (ICACCI)*, 2019, pp. 456–462.
- [13] K. Patel, N. Shah, and A. Mehta, "IoT-based vehicle monitoring and accident detection system," in *IEEE Int. Conf. Intelligent Communication and Computational Techniques (ICCT)*, 2020, pp. 144–148.
- [14] M. R. Khan, T. Alam, and R. S. Chauhan, "Accident detection with accelerometer GSM modules in smart vehicles," in *IEEE Int. Conf. Smart City and Emerging Technologies (ICSCET)*, 2019, pp. 1–6.
- [15] P. Banerjee and R. Ghosh, "AI-based accident detection based on smartphone data and deep learning," *IEEE Access*, vol. 10, pp. 35789–35799, 2022.
- [16] S. Choudhury, A. Pal, and V. Menon, "Edge-AI powered accident detection with GSM alerting," in *IEEE Int. Conf. Smart IoT Systems (SIoT)*, 2021, pp. 75–82.