

GSM Based Smart Safety and Remote-Control System for Small and Medium Enterprises (SMEs)

Shreya Patil¹, Gayatri Daware², Kartik Ingle³, Prathmesh Wankhede⁴

¹²³⁴ Final Year Students, Department of Electronics and Telecommunication Engineering, Mauli Group of Institution College of Engineering and Technology, Shegaon, SGBAU, Amravati, India.

Prof. K. S. Bhoyar⁵

⁵ Assistant Professor, Department of Electronics and Telecommunication Engineering, Mauli Group of Institution College of Engineering and Technology, Shegaon, SGBAU, Amravati, India.

¹gayatridaware2509@gmail.com



<https://doi.org/10.55041/ijstmt.v2i5.119>

Cite this Article: Patil, S., Daware, G., Ingle, K. & Wankhede, P. (2026). GSM Based Smart Safety and Remote-Control System for Small and Medium Enterprises (SMEs). International Journal of Science, Strategic Management and Technology, 02(05). <https://doi.org/10.55041/ijstmt.v2i5.119>

License:  This article is published under the Creative Commons Attribution 4.0 International License (CC BY 4.0), permitting use, distribution, and reproduction in any medium, provided the original author(s) and source are properly credited.

Abstract

This system presents an IoT-based industrial safety and remote monitoring system designed to detect hazardous conditions such as gas leakage and fire. The system uses sensors interfaced with an Arduino UNO to continuously monitor the environment. When a hazard is detected, the system automatically controls devices through a relay module and sends alert messages to the user via a GSM module.

The system ensures fast response, reliable detection and remote communication, making it a cost-effective solution for improving industrial safety and reducing risks.

I. INTRODUCTION

Industrial environments involve hazardous conditions such as gas leakage, fire and equipment failure, which can pose serious risks to safety and operations. Traditional safety methods rely on manual monitoring, which may lead to delays and human error. Therefore, there is a need for an automated system that can continuously monitor conditions and respond instantly.

This system presents an industrial safety and remote monitoring system using Arduino, sensors and a GSM module. The system detects hazards like gas leakage and fire, controls devices through a relay module and sends alert messages to the user. The system is capable of detecting gas leakage and fire, automatically controlling industrial devices and sending alert messages to the user's mobile phone.

This integration of sensing, processing and communication enhances safety by ensuring quick response and remote awareness. It provides a simple, cost-effective and reliable solution to improve safety and reduce risks in industrial environments.

Keywords

GSM Technology, Industrial Safety, Arduino Uno, MQ-2 Sensor, Flame.

II. LITERATURE REVIEW

Industrial safety and monitoring systems using sensor-based technologies are widely used to improve hazard detection, response time and operational safety in industrial environments [1] [2]. Systems based on Arduino and multi-sensor integration provide real-time monitoring of parameters such as gas leakage and fire, ensuring quick and automated response to dangerous situations [2] [3]. GSM-based communication systems are commonly implemented to enable remote alerting and user notification during emergencies, improving response efficiency even in remote locations [3] [4]. Additionally, IoT-based industrial monitoring systems enhance data accessibility and remote-control capabilities, allowing users to monitor and manage systems from anywhere [4] [5].

III. WORKING PRINCIPLE

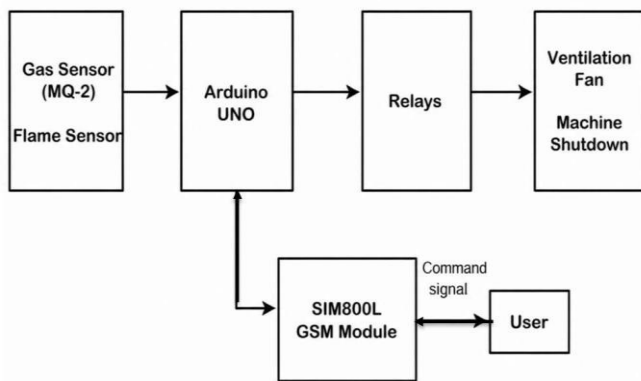

Fig.1.1: Block Diagram

The system operates by continuously monitoring the environment using a gas sensor and a flame sensor. These sensors detect the presence of harmful gases and fire and convert these physical conditions into electrical signals. The signals are then sent to the Arduino UNO for processing.

The Arduino UNO acts as the control unit, where it reads the sensor data and compares it with predefined threshold values. Under normal conditions, the system remains in monitoring mode.

When a hazardous condition such as gas leakage or flame is detected, the Arduino immediately processes the input and triggers the relay module.

The relay module controls connected devices such as switching OFF machines or turning ON a ventilation fan to reduce risk. At the same time, the Arduino communicates with the GSM module, which sends an alert message to the user's mobile phone. This ensures quick response, automatic control and remote notification for improved safety.

IV. IMPLEMENTATION

The implementation of the system involves designing and integrating both hardware and software components to achieve effective industrial safety monitoring. The hardware setup includes the Arduino UNO as the main controller, MQ-6 gas sensor, flame sensor, relay module, GSM module (SIM800L), voltage regulators (7805/7809), buck converter and a 12V power supply. All components are connected according to the circuit diagram, ensuring proper voltage levels are maintained for each device. The sensors are interfaced with the input pins of the Arduino, while the relay module is connected to the output pins for controlling external loads. The GSM module is connected through serial communication (TX/RX pins) for sending alert messages.

The software implementation is carried out using the Arduino IDE, where the program is written in embedded C. The code is designed to continuously read input signals from the gas and flame sensors and compare them with predefined threshold values. Calibration of sensors is performed to ensure accurate detection. When the sensed values exceed the safe limits, the Arduino executes control logic to activate the relay module and send AT commands to the GSM module for message transmission.

During system operation, the sensors continuously monitor environmental conditions and send real-time data to the Arduino. In the event of gas leakage or fire detection, the system immediately responds by activating

the relay module to control devices such as switching OFF machines or turning ON a ventilation fan. Simultaneously, the GSM module sends an alert message to the user's mobile phone, providing remote notification. The system automatically resets once the conditions return to normal and continues monitoring without interruption. This implementation ensures reliable performance, quick response and effective integration of sensing, control and communication for industrial safety applications.

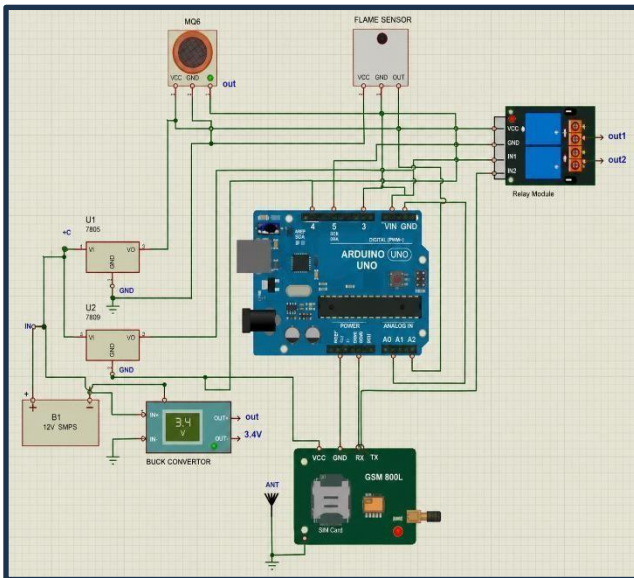
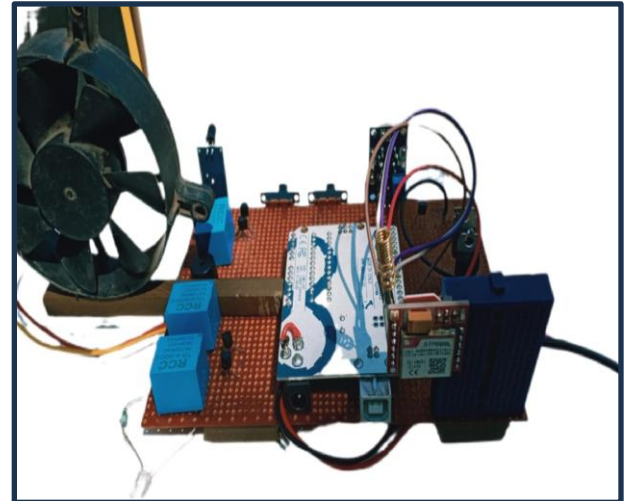

Figure 1.2: Circuit Diagram

V. RESULT AND DISCUSSION

The system was tested under different conditions and successfully detected hazardous situations such as gas leakage and fire using the MQ-6 gas sensor and flame sensor. The Arduino Uno processed the sensor inputs efficiently and responded immediately when the detected values exceeded the set thresholds. The relay module operated correctly by controlling connected devices, such as switching OFF machines and activating the ventilation fan during unsafe conditions. The GSM module also worked reliably by sending alert messages to the user's mobile phone within a short time. The overall system performance was stable and it showed a quick response during testing. Under normal conditions, the system remained in monitoring mode without triggering false actions, indicating proper calibration and programming.



VI. CONCLUSION

The developed system demonstrates an effective solution for industrial safety by integrating gas and flame sensors with a microcontroller-based control and communication system. It successfully detects hazardous conditions such as gas leakage and fire, processes the information using the Arduino Uno and takes immediate action through the relay module to control connected devices.

The system also ensures remote monitoring by sending alert messages to the user via the GSM module, enabling quick response even from a distance. The overall performance is reliable, with fast response time and stable operation under different test conditions.

REFERENCES

- [1] Kurniawan and D. Prasetyo, "IoT-Based Fire Detection System Using Arduino," *Journal of Smart Systems Engineering*, Vol. 5, No. 2, 2024.
- [2] Y. Chen and H. Li, "Low-Cost Industrial Safety Monitoring Systems for Small Enterprises," *IEEE Access*, Vol. 11, 2023.
- [3] T. R. Ramesh and K. Saravanan, "Design and Implementation of Low-Cost Gas Leakage and Fire Alert System for Small Scale Industries," *IEEE Exploratory Reports in Industrial Technology*, Vol. 12, 2023.

- [4] S. Verma and R. Singh, "Design Arduino-Based Multi-Sensor Safety System for Industrial Application," *International Journal of Engineering Research & Technology (IJERT)*, Vol. 12, No. 6, 2023.
- [5] P. Kumar and S. Tiwari, "Design and Implementation of Smart Industrial Safety System Using Arduino and GSM," *International Journal of Computer Applications*, Vol. 183, No. 12, 2023.
- [6] Sharma and D. Mehta, "Automation and Safety Enhancement in SMEs Using Microcontroller- Based Systems," *Journal of Industrial Engineering and Management*, Vol. 16, No. 1, 2023.
- [7] R. Kumar and V. Singh, "Implementation of Smart Safety System Using GSM and Sensors," *International Journal of Advanced Research in Computer Science*, Vol. 14, No. 2, 2023.
- [8] L. Brown and T. Wilson, "Low-Cost Embedded Monitoring Systems for Small-Scale Industries," *IEEE Transactions on Industrial Electronics*, Vol. 70, No. 5, 2023.
- [9] T. R. Ramesh and K. G. Saravanan, "Design and Implementation of Low-Cost Gas Leakage and Fire Alert System for Small Scale Industries," *IEEE Exploratory Reports in Industrial Technology*, Vol. 12, 2023.
- [10] V. M. Thorat and S. P. Deshmukh, "GSM Based Smart Industrial Safety and Remote Control for SME Sector," *International Journal of Research in Engineering, Science and Management*, Vol. 6, No. 3, 2023.
- [11] S. Das and A. Roy, "Sensor-Based Hazard Detection System for Industrial Applications," *International Journal of Electronics and Communication Engineering*, Vol. 11, No. 4, 2022.
- [12] B. Ram and K. Reddy, "GSM Based Smart Safety System for SMEs," *International Journal of Engineering Research*, Vol. 10, 2022.
- [13] F. Garcia and M. Lopez, "A Survey on Industrial Safety Monitoring using Embedded Platforms," *Journal of Systems Engineering*, Vol. 19, 2022.
- [14] R. Singh and V. Patel, "Gas Leakage Detection System Using MQ Sensors for Industrial Safety," *International Journal of Scientific Research in Engineering and Management (IJSREM)*, Vol. 5, 2021.
- [15] Ali and K. Hussain, "Development of GSM-Based Remote Monitoring and Control System," *International Journal of Engineering Science and Technology*, Vol. 15, No. 3, 2021.