

Smart Panic Button using IOT

Blessy.J¹, Dr.Vishwa Priya.V²

Student, Department of Computer Science and Information Technology .Vels Institute of Science, Technology and Advanced Studies Chennai, India¹

Assistant Professor, Department of Computer Science and Information Technology, Vels Institute of Science, Technology and Advanced Studies, Chennai, India²



<https://doi.org/10.55041/ijst.v2i4.640>

Cite this Article: Blessy.J, (2026). Smart Panic Button using IOT. International Journal of Science, Strategic Management and Technology, 02(04).
<https://doi.org/10.55041/ijst.v2i4.640>

License:  This article is published under the Creative Commons Attribution 4.0 International License (CC BY 4.0), permitting use, distribution, and reproduction in any medium, provided the original author(s) and source are properly credited.

ABSTRACT

The increasing need for rapid emergency response systems has led to the development of intelligent safety solutions. This paper presents a Smart Panic Button system based on Internet of Things (IoT) technology, designed to provide immediate assistance during critical situations. The proposed system enables users to trigger an alert by pressing a panic button, which instantly sends real-time notifications to predefined contacts and emergency services through a cloud-based platform. The system integrates a microcontroller, GPS module, and wireless communication technologies to transmit the user's precise location along with the distress signal. Additionally, a mobile or web application interface is developed to monitor alerts and manage user data efficiently. The solution ensures low latency, reliability, and ease of use, making it suitable for individuals in vulnerable situations such as medical emergencies, personal safety threats, or accidents. By leveraging IoT connectivity, the Smart Panic Button enhances response time and improves the effectiveness of emergency assistance systems. The proposed model is cost-effective, scalable, and adaptable for real-world deployment, contributing to improved public safety and security.

INTRODUCTION

In today's world, personal safety has become a major concern due to the increasing number of crimes, accidents, and health-related emergencies. Quick response during such situations is crucial to prevent serious consequences. However, traditional methods of seeking help, such as making phone calls or sending messages, may not always be effective, especially when the user is in panic or unable to communicate properly. This creates a need for a fast and reliable emergency alert system. The Internet of Things (IoT) has emerged as a powerful technology that connects devices and enables real-time communication. IoT-based systems allow devices to send and receive data instantly, making them suitable for emergency applications. By using IoT, it is possible to design systems that can automatically send alerts without requiring complex user interaction. The Smart Panic Button using IoT is a system developed to provide immediate assistance during emergencies. The system consists of a panic button, microcontroller, GPS module, and communication module such as GSM or Wi-Fi. When the user presses the panic button, the system sends an alert message along with the user's real-time location to predefined contacts or emergency services. This helps responders quickly identify the location and provide timely assistance. One of the key advantages of this system is its simplicity and ease of use. The single-button operation makes it accessible to people of all ages. It is also cost-effective and portable, making it suitable for everyday use. In conclusion, the Smart Panic Button using IoT is an effective solution for improving personal safety by ensuring quick alerts and accurate location tracking during emergency situations.

LITERATURE REVIEW

With the rapid growth of Internet of Things (IoT) technology, several emergency alert systems have been developed to improve personal safety and reduce response time. Many researchers have focused on designing smart systems that can send alerts quickly during critical situations. Earlier systems were mainly based on GSM technology, where users could send SMS alerts to predefined contacts. Although these systems were simple, they had limitations such as delay in message delivery and lack of real-time location tracking. To overcome these issues, researchers introduced GPS-based tracking systems, which enabled users to share their exact location along with the alert message. Recent studies have explored IoT-based panic button systems that integrate microcontrollers such as Arduino or ESP32 with cloud platforms. These systems allow real-time data transmission and remote monitoring through mobile or web applications. Some designs also include additional features like sensors for automatic detection of emergencies. These systems have shown improved efficiency, faster communication, and better reliability compared to traditional methods. Several works have also focused on women's safety applications, where wearable devices or mobile-based panic buttons are used to send alerts. However, mobile-based solutions depend on internet connectivity and user interaction, which may not be reliable in all situations. IoT-based standalone devices provide a more effective solution by enabling instant alerts with minimal user effort. Despite these advancements, existing systems still face challenges such as high cost, complexity, and dependency on network availability. Some systems also lack user-friendly design and portability. Based on the literature, it is clear that IoT-based panic button systems offer a promising approach for emergency response. The proposed system aims to provide a simple, cost-effective, and reliable solution with real-time alert and location tracking features.

METHODOLOGY

1. System Initialization and Monitoring

All components such as the microcontroller, GPS module, and communication module are initialized. The system remains in standby mode and continuously monitors the panic button for user input.

2. Emergency Trigger Detection

When the panic button is pressed, the microcontroller detects the signal and immediately activates the emergency response process.

3. Location Acquisition and Processing

The GPS module retrieves the user's real-time location coordinates (latitude and longitude). The microcontroller processes this data and prepares an alert message with location details.

4. Alert Transmission via IoT

The system sends the emergency alert along with the location through Wi-Fi or GSM. The data may also be transmitted to a cloud platform for real-time monitoring and storage.

5. Notification and System Reset

Predefined contacts receive the alert via SMS or mobile application. A buzzer or LED indicates successful transmission, and the system resets back to standby mode for future use.

IMPLEMENTATION

The core working principle of this project is based on wireless communication using the Internet of Things (IoT) to control electrical devices remotely. The implementation of the Smart Panic Button using IoT involves the integration of both hardware and software components to ensure efficient and real-time emergency alert communication. The system is developed using a microcontroller such as ESP8266 or ESP32, which acts as the central processing unit. A panic push button is connected as the input device, while a GPS module (NEO-6M) is used to obtain the user's real-time location. For communication, either a GSM module (SIM800L) or Wi-Fi is used to transmit alert messages. Additional components like a buzzer or LED are included to provide feedback indicating the status of the system. On the software side, the microcontroller is programmed using the Arduino IDE with Embedded C/C++ language. The program is designed to

initialize all modules, continuously monitor the panic button, and execute the alert process when the button is pressed. When triggered, the system retrieves GPS coordinates and formats them into a readable emergency message, often including a location link. The IoT functionality enables the system to send alerts either through SMS using GSM or via internet-based platforms such as Firebase or ThingSpeak. These alerts are delivered instantly to predefined contacts through mobile phones or web applications. The system is tested under different conditions to ensure accuracy, reliability, and quick response. The results show that the system effectively sends alerts with minimal delay, making it suitable for real-time emergency situations.

WORKING PRINCIPLE

The Smart Panic Button using IoT is designed to provide immediate assistance during emergency situations through real-time communication and location tracking. The system works by continuously monitoring the panic button and, upon activation, sending a distress alert along with the user's current location to predefined contacts. It uses a microcontroller, GPS module, and communication module (GSM/Wi-Fi) to ensure fast and reliable transmission of data. The integration of IoT enables remote monitoring and quick response, making the system efficient and user-friendly.

Block Diagram:

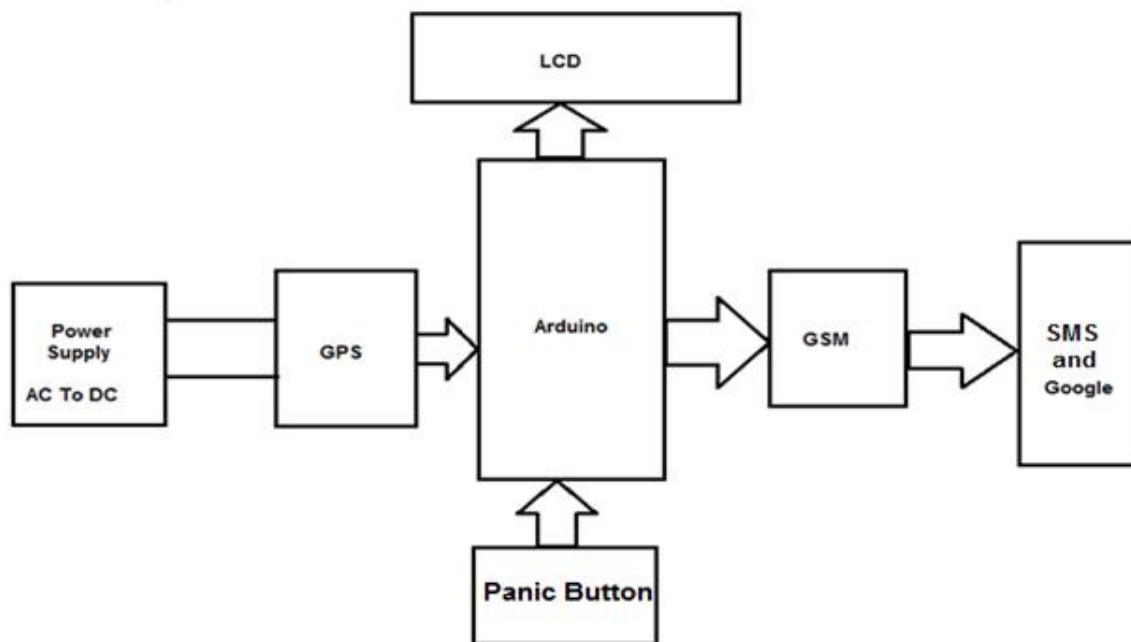

Step-by-Step Operation:

1. System Initialization and Monitoring

When the device is powered ON, all components such as the microcontroller, GPS module, and communication module (GSM/Wi-Fi) are initialized. The system enters standby mode and continuously monitors the panic button, ensuring it is always ready to respond instantly during an emergency.

2. Emergency Trigger Detection

When the user presses the panic button, the microcontroller detects the input signal immediately. This action triggers the emergency process without requiring any additional user interaction, making the system fast and user-friendly.

3. Location Acquisition

After activation, the GPS module retrieves the user's real-time location in the form of latitude and longitude coordinates. This step is crucial for identifying the exact position of the user during an emergency.

4. Data Processing and Alert Transmission

The microcontroller processes the GPS data and formats it into a readable emergency alert message, often including a map link. This message is then transmitted via the communication module (GSM/Wi-Fi) to predefined contacts or uploaded to a cloud platform for real-time monitoring.

5. Notification and System Reset

The emergency contacts receive the alert message along with the user's location through SMS or a mobile application. A buzzer or LED indicator confirms successful transmission to the user. After completing the process, the system automatically resets and returns to standby mode, ready for future use.

RESULT

The Smart Panic Button using IoT system was successfully designed and implemented, and its performance was tested under different emergency scenarios. The system was able to detect the panic button press instantly and trigger the alert process without delay. The GPS module accurately captured the user's real-time location in the form of latitude and longitude coordinates. This location data was successfully included in the alert message, allowing recipients to easily identify the exact position of the user. In most test cases, the communication module (GSM/Wi-Fi) transmitted the alert message within a few seconds, demonstrating fast and reliable performance. The alerts were received by predefined contacts through SMS or mobile/web applications without failure. The inclusion of a map link further improved usability by enabling quick navigation to the user's location. The buzzer/LED indicator also functioned properly, providing confirmation that the alert had been sent successfully.

The system showed high reliability and efficiency, with minimal delay depending on network conditions. It performed consistently in real-time conditions and proved to be user-friendly and easy to operate. Overall, the results confirm that the Smart Panic Button using IoT is an effective solution for emergency alert systems, providing quick communication and accurate location tracking, thereby improving response time and user safety.

Key Results Achieved:

1. The system successfully detected the panic button press instantly and triggered the emergency alert without delay.
2. Accurate real-time location (latitude and longitude) was obtained using the GPS module.
3. Emergency alert messages were transmitted quickly through GSM/Wi-Fi to predefined contacts.
4. Alerts were received successfully via SMS or mobile/web applications with minimal delay.
5. The inclusion of a map link enabled easy tracking of the user's exact location.
6. The system demonstrated high reliability and consistent performance under different test conditions.
7. The buzzer/LED indicator provided proper confirmation of alert transmission.
8. The overall system proved to be user-friendly, cost-effective, and suitable for real-time emergency situations.

CONCLUSION

The Smart Panic Button using IoT is an effective and reliable solution designed to enhance personal safety during emergency situations. The system enables users to send instant alerts along with their real-time location to predefined contacts with just a single button press. By integrating a microcontroller, GPS module, and communication technologies such as GSM or Wi-Fi, the system ensures fast and accurate transmission of information. One of the major advantages of this system is its simplicity and ease of use, making it accessible to people of all age groups. It reduces the dependency

on smartphones and minimizes the time required to communicate during critical situations. The real-time location tracking feature helps responders quickly identify the user's position, thereby improving the chances of timely assistance. The system is cost-effective, portable, and suitable for various applications such as women's safety, elderly care, and accident alert systems. The use of IoT technology enhances the overall efficiency and reliability of the system by enabling real-time communication and monitoring. In conclusion, the Smart Panic Button using IoT provides a practical and efficient approach to emergency response. With further improvements such as integration with mobile applications, wearable devices, and advanced technologies, the system can be widely adopted to create a safer and more secure environment for individuals.

REFERENCES

1. Raj Kamal, Internet of Things: Architecture and Design Principles, McGraw Hill Education, 2017.
2. IEEE, "IoT-Based Smart Emergency Alert Systems," IEEE Xplore Digital Library, 2020–2023.
3. Arduino Official Documentation, "Arduino Programming and Microcontroller Basics," Available at: <https://www.arduino.cc>
4. Espressif Systems, "ESP8266/ESP32 Technical Reference Manual," Available at: <https://www.espressif.com>
5. Google, "Firebase Documentation for Real-Time Database," Available at: <https://firebase.google.com>
6. GPS Module (NEO-6M) Datasheet, u-blox AG, Switzerland.
7. GSM Module (SIM800L) Datasheet, SIMCom Wireless Solutions.
8. Research Papers on IoT-based Safety and Emergency Systems, available on platforms like Google Scholar and ResearchGate.